

Instructions for Duplex Drums Hamilton Drum Seeder

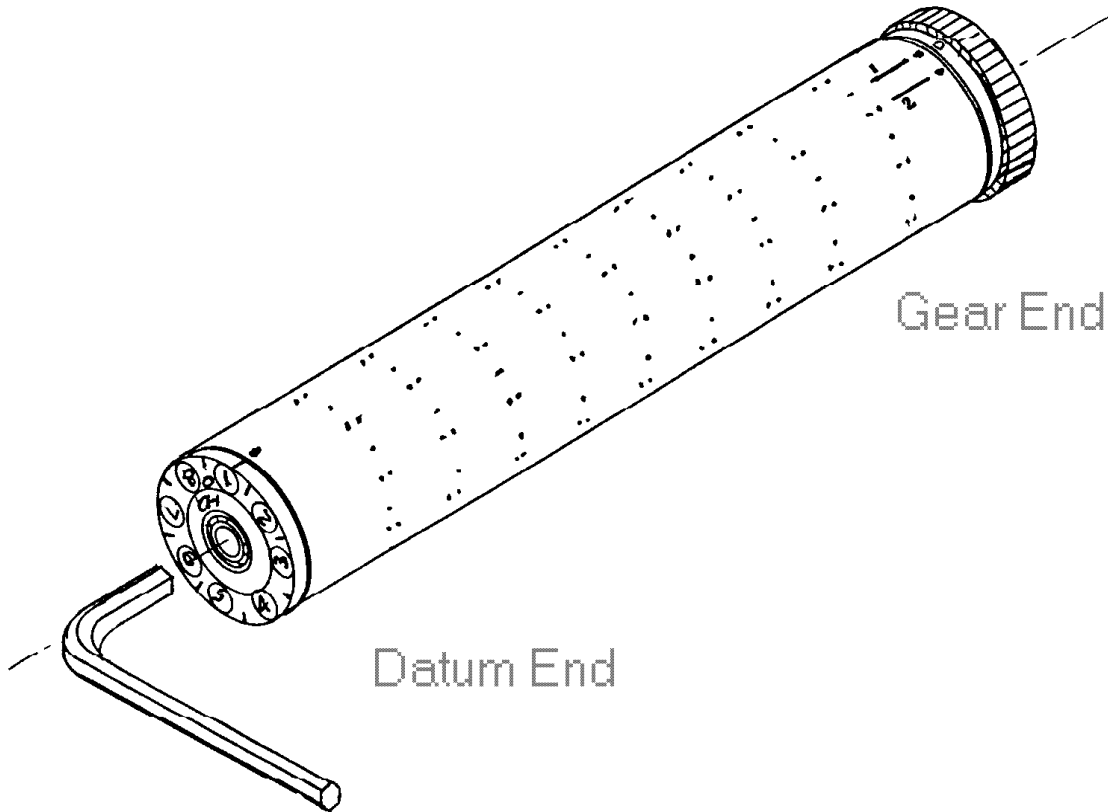

To change rows

- 1) Locate 5mm A/F hex key in the datum end of the drum as indicated, and loosen the cap head screw one turn only.
- 2) Align the mark at the gear end with the line on the drum surface to connect the appropriate line of holes, and tighten the cap head screw.

Timing

The timing marks on the datum end of the drum numbered 1 to 8 correspond to the primary line of holes (as indicated on line 1 of the drawing). When the secondary holes (line 2) are used, the timing marks between the numbers should be used.

Drum Cleaning

The internal galleries of the drum can be cleaned by removing the drum ends completely. Undo the screw in the datum end 10 turns, and loosen the datum end by pushing on the gear end. Undo the screw completely, remove the datum end, and withdraw the gear end and tie rod.

The galleries can now be cleaned with a cleaning brush. The gear end ports can be cleaned with a cotton bud.

When reassembling the drum, take care to align the number 1 timing mark with the dimple on the drum surface.

Two cleaning wires are provided. Tear the tape about 6-8 mm along the line of the wire and fold the corners over to expose the wire. With care (and a bit of patience!) the wire can be inserted into the drum holes to clean them.